

PERFECT FRY DSE MODELS

VENTLESS/HOODLESS COUNTERTOP DEEP FRYER

## Advanced by Design



- SELF VENTING
- HEPA STYLE AIR FILTRATION
- PROGRAMMABLE CONTROLS
- EASY TO CLEAN
- SMALL FOOTPRINT
- LARGE OUTPUT
- MODULAR DESIGN

PHONE: 403-255-7712

TOLL FREE: 800-265-7711

ADDRESS: 9298 Horton Road S.W., Calgary, AB, Canada T2V 2X4

FAX: 403-255-1725

E-MAIL: [profits@perfectfry.com](mailto:profits@perfectfry.com)

WEB: [www.perfectfry.com](http://www.perfectfry.com)



## CLEARANCES

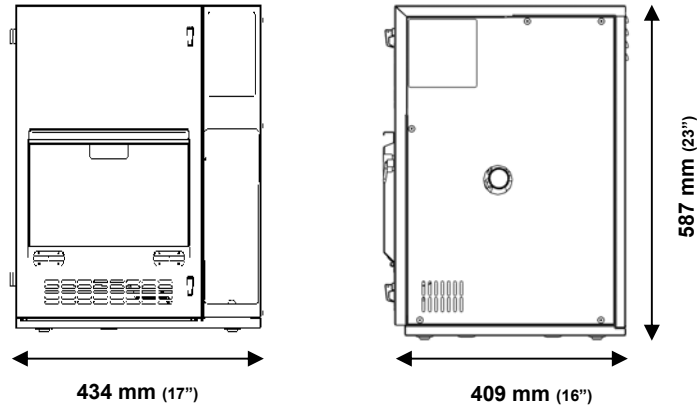

## AIRFLOW DIAGRAM

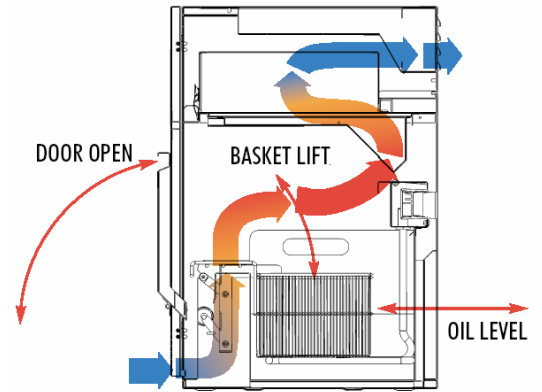

## SPECIFICATIONS TABLE

MODEL	DSE5700SS	DSE5700BF	DSE3000SS	DSE3000BF
POWER SUPPLY volts	240	240	240	240
CURRENT amps	24	24	12.5	12.5
CIRCUIT CURRENT amps	30	30	15	15
POWER kilowatts	5.7	5.7	3.0	3.0
CAPACITY kg/hr. (lbs/hr.)	20(45)	20(45)	10(22)	10(22)
BASKET INCLUDED	1 Extra Large	1 Extra Large	1 Extra Large	1 Extra Large
EXTERIOR FINISH	Stainless Steel	Powdercoat	Stainless Steel	Powdercoat

## GENERAL SPECIFICATIONS

- Phase Single (3 wire)
- Cycles 50/60 Hz
- Weight 36 kg (80 lbs.)
- Shipping Weight 42 kg (96 lbs.)
- Shipping Dimensions Depth 559mm (22")  
Width 559mm (22")  
Height 686mm (27")
- Shipping Cube .214m<sup>3</sup> (7.56 ft<sup>3</sup>)
- Oil Capacity 8L (2 US Gallons)



Powdercoat Model



Stainless Steel Model

## BASKET

EXTRA LARGE (32oz/6 servings)

