

PROJECT	QUANTITY	ITEM NO
---------	----------	---------

# Display counter warmers

## Two-tier, dry over humidified

MODEL **CWH-23** two tier, 5-pan  
**CWH-35** two tier, 8-pan



CWH-23 two-tier display counter warmer with flip-up pass-through doors and lower-tier moist heat operation.

### General Information

The Henny Penny two tier counter warmers are designed specifically for serving and displaying hot food at the point of sale in retail foodservice operations. Units feature high product visibility, pass-through operation, and water-well humidity control.

These attractive, dependable humidified countertop warmers offer practical pass-through convenience while keeping hot food items fresh, appetizing and on display for customer impulse purchases.

The CWH two-tier models also offer a combination of separate holding environments. The unit's lower tier features moist heat operation from a heated, auto-fill reservoir in the base. Upper tiers operate with dry radiant heat, only. Temperatures for each tier are controlled separately.

Tough acrylic flip up doors offer excellent product visibility and convenient pass-through access—a must for high-volume service.

Units are built from high-quality stainless steel and are insulated for energy-efficient operation.

### Standard Features

- Stainless steel interior and exterior construction for easy cleaning and long-lasting service.
- Available in two sizes: 5-pan or 8-pan capacity.
- Lower tier features moist heat humidified operation.
  - Water reservoir runs length of unit with automatic or manual fill.
  - Two water well strip heaters.
  - Low water indicator light.
  - Drain tube prevents water well overflow.
  - Water temperature display and control.
- Upper tier operates dry.
- Long-lasting sheath radiant heaters.
- Insulated top and bottom for energy efficient operation.
- Independent heating controls for each tier hold different foods at optimum temperatures.
- Water temperature display and control.
- Tough, durable acrylic flip-up door panels for see-through, pass-through operation.
- Incandescent lighting for appealing food display.
- Removable access panels for easy maintenance.

<input type="checkbox"/> APPROVED	<input type="checkbox"/> APPROVED AS NOTED	<input type="checkbox"/> RESUBMIT
AUTHORIZED SIGNATURE		DATE



PROJECT	ITEM NO
---------	---------

# Display counter warmers

## Two-tier, dry over humidified

MODEL **CWH-23** two tier, 5-pan  
**CWH-35** two tier, 8-pan

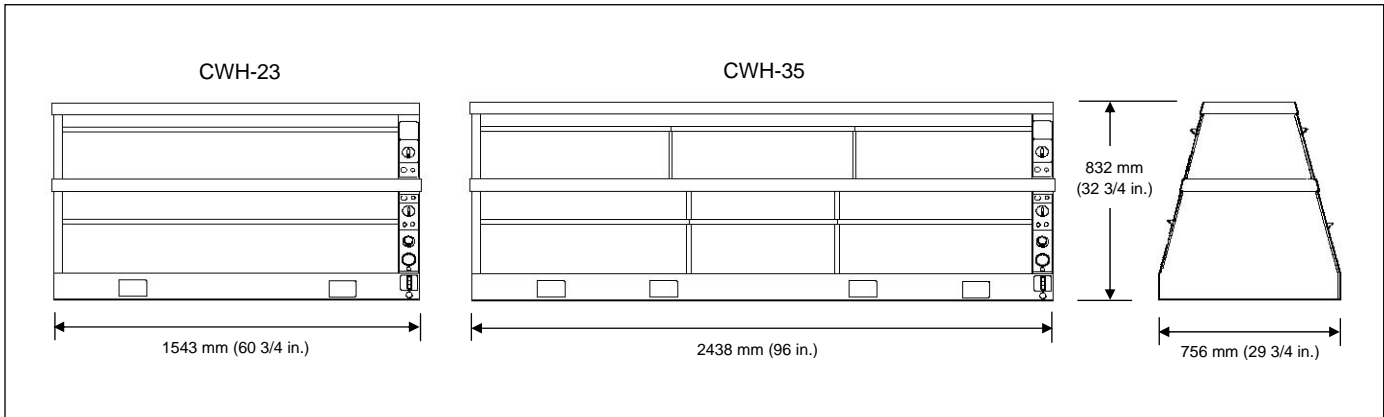

### Dimensions

	CWH-23	CWH-35
Length	1543 mm (60 3/4 in.)	2438 mm (96 in.)
Depth	756 mm (29 3/4 in.)	756 mm (29 3/4 in.)
Height	832 mm (32 3/4 in.)	832 mm (32 3/4 in.)

Required clearances: N/A

### Crated dimensions

	CWH-23	CWH-35
Length	1584 mm (62 3/8 in.)	2502 mm (98 1/2 in.)
Depth	829 mm (32 5/8 in.)	959 mm (37 3/4 in.)
Height	991 mm (39 in.)	1029 mm (40 1/2 in.)
Volume	1.29 m <sup>3</sup> (46 cu. ft.)	2.44 m <sup>3</sup> (87 cu. ft.)

Net weight: N/A

### Crated weight

CWH-23	147 kg (335 lbs.)
CWH-35	260 kg (594 lbs.)

Water connections: 1/4 in. hot water supply, drain.

Humidity: Auto-fill water pan in lower tier. Upper tier operates dry.

CWH-23	38 liter (10 gal) reservoir
CWH-35	57 liter (15 gal) reservoir

Capacity: Full size sheet pans, 457 x 660 mm (18 x 26 in.)

	CWH-23	CWH-35
Upper tier	2 sheet pans crosswise	3 sheet pans crosswise
Lower tier	3 sheet pans lengthwise	5 sheet pans lengthwise

### Electrical

Model	Volts	Phase	Cycle/Hz	Watts	Amps	Wire
CWH-23	380-415	3	50-60	4466	6.2	4+G
CWH-35	380-415	3	50/60	8920	12.4	4+G

NOTE: Units must be hard-wired at site by qualified technician

### Bidding Specifications

- Provide Henny Penny model CWH-23 or CWH-35 two-tiered display counter warmer for accumulating, holding and displaying freshly cooked food prior to serving.
- Units feature flip-up door panels on both sides for easy pass-through operation.
- CWH-23 shall hold up to 5 full size sheet pans. CWH-35 shall hold up to 8 full size sheet pans.
- Lower tier operates with heated water pan humidity. Water provided by hot water connection and auto-fill reservoir. Upper tier operates dry. Both tiers feature thermostat controlled upper radiant heaters.
- Materials—interior and exterior of welded stainless steel. Flip-up doors on both sides of scratch-resistant acrylic.
- Units shall have rear-mounted control panel with independent temperature control for upper and lower tiers.

Continuing product improvement may subject specifications to change without notice.

Henny Penny Corporation  
 PO Box 60 Eaton OH 45320 USA  
 +1 937 456.8400 800 417.8417  
 +1 937 456.8434 Fax 800 417.8434 Fax  
[www.hennypenny.com](http://www.hennypenny.com)

**HENNY PENNY**

This product manufactured in Suzhou, China